

### Description

The Si4712/13 is the industry's first 100% CMOS FM radio transmitter with an integrated receiver to measure receive signal strength. The device leverages Silicon Labs' highly successful and proven Si4700/01 FM receiver, and offers unmatched integration and performance allowing FM transmit to be added to any portable device by using a single chip. As with the Si4700/01, the Si4712/13 offers industry leading size, performance, low power consumption, and ease of use.

The Si4712/13's digital integration reduces the required external components of traditional offerings, resulting in a solution requiring only an external inductor and bypass capacitor, and PCB space of approximately 15 mm<sup>2</sup>. High reliability in device manufacturing, improved quality, easy design-in, and software programmability are key advantages of the Si4712/13.

The Si4713 supports the European Radio Data System (RDS) and the US Radio Broadcast Data System (RBDS) standards including all the symbol encoding, block synchronization, and error correction functions. Using this feature, the Si4713 enables data such as artist name and song title to be transmitted to an RDS/RBDS receiver.

Users are responsible for adjusting their system's radiated power levels to comply with local regulations on RF transmission (FCC, ETSI, ARIB, etc.).

### Features

- Integrated receiver for receive power measurement
- Worldwide FM band support (76–108 MHz) for transmit
- Requires only two external components
- Frequency synthesizer with integrated VCO
- Digital stereo modulator
- Programmable pre-emphasis (50/75  $\mu$ s)
- Analog/digital audio interface
- Programmable reference clock
- RDS/RBDS transmit encoder (Si4713 only)
- PCB loop antenna support with self calibrated capacitor tuning
- Programmable transmit level
- Programmable modulation
- 2.7 to 5.5 V supply voltage
- Digital gain compression
- Integrated LDO regulator
- 3 x 3 x 0.55 mm 20-pin QFN
  - Pb-free and RoHS Compliant

### Applications

- Cellular handsets/hands-free
- MP3 players
- Portable audio/video players
- Wireless speakers/microphone
- Satellite digital audio radios
- Personal computers/notebooks

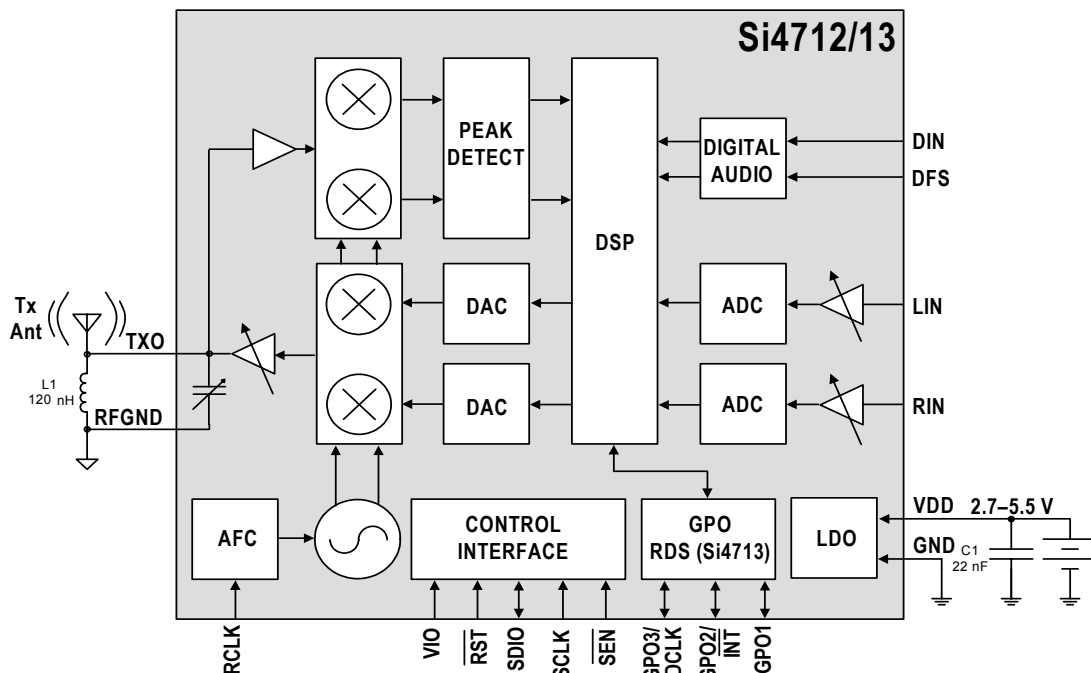

### Selected Electrical Specifications

Parameter	Symbol	Test Condition	Min	Typ	Max	Unit
Transmit Frequency Range	$f_{RF}$		76	—	108	MHz
Programmable Transmit Output Voltage, TXO			—	118	—	dB $\mu$ V
Transmit Voltage Accuracy		$V_{RF} = 102\text{--}118\text{ dB}\mu\text{V}$	-2.5	—	2.5	dB
Transmit Voltage Step			—	1	2	dB
Transmit Channel Edge Power			—	—	-20	dBc
Transmit Adjacent Channel Power			—	-30	-26	dBc
Pre-Emphasis Time Constant		TX_PREMPHASIS = 75 $\mu$ s	70	75	80	$\mu$ s
		TX_PREMPHASIS = 50 $\mu$ s	45	50	54	$\mu$ s
Audio SNR Mono			—	63	—	dB
Audio THD Mono			—	0.1	0.5	%
Audio Stereo Separation			30	35	—	dB
Sub Carrier Rejection Ratio	SCR		40	50	—	dB
Input Signal Level (0 dB)	$V_{AI}$		—	—	0.636	$V_{pk}$
Audio Bandwidth (3 dB)			30	—	15 k	Hz
Audio Imbalance			-1	—	1	dB
Powerup Settling Time		From Powerdown	—	—	110	ms
Supply Voltage	$V_{DD}$		2.7	—	5.5	V
Interface Supply Voltage	$V_{IO}$		1.5	—	3.6	V
TX Supply Current	$I_{TX}$	FM TX from Line Input	—	18.8	22.8	mA
TX Interface Supply Current	$I_{IO}$		—	320	600	$\mu$ A

### Pin Assignments

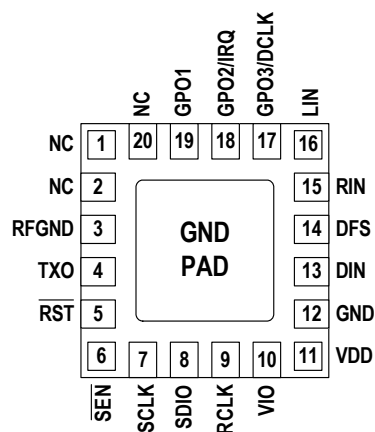

### Package Information

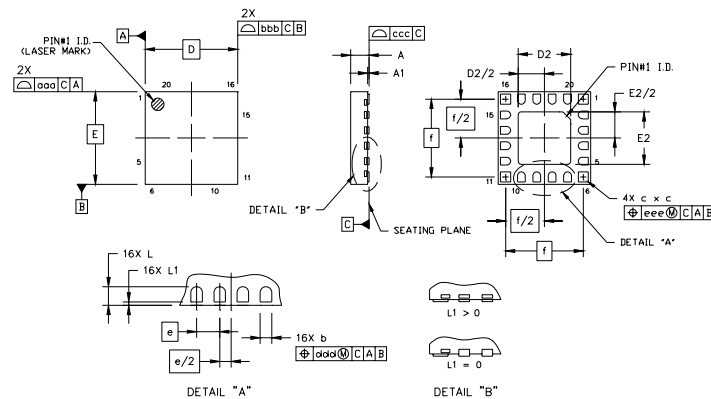

Symbol	Millimeters		
	Min	Nom	Max
A	0.50	0.55	0.60
A1	0.00	0.02	0.05
b	0.20	0.25	0.30
c	0.27	0.32	0.37
D	3.00 BSC		
D2	1.65	1.70	1.75
e	0.50 BSC		
E	3.00 BSC		
E2	1.65	1.70	1.75

Symbol	Millimeters		
	Min	Nom	Max
f	2.53 BSC		
L	0.35	0.40	0.45
L1	0.00	—	0.10
aaa	—	—	0.05
bbb	—	—	0.05
ccc	—	—	0.08
ddd	—	—	0.10
eee	—	—	0.10